

PARTS

(A)	LEFT SIDE PANEL	(M)	SMALL DOWELS (12)
(B)	RIGHT SIDE PANEL	(N)	LARGE DOWELS (20)
(C)	DIVIDER	(O)	HINGE PINS (2)
(D)	BASE	(P)	MACHINE SCREWS (6)
(E)	TOP	(Q)	HANDLES (3)
(F)	BACK	(R)	PULL
(G)	DOOR	(S)	CAM-BOLTS (8)
(H)	TRAY	(T)	CAM-LOCKS (8)
(I)	SHORT CROSS BARS (3)	(U)	COVERS (4)
(J)	MAGAZINE CROSS BAR	(V)	SHELF SUPPORTS (4)
(K)	FRONT CROSS BAR	(W)	BACK CROSS BAR
(L)	SHELF		

Thank you for purchasing this quality product. Be sure to check all packing material carefully for small parts which may have come loose inside the carton during shipment. Separate, identify, and count all parts and metal hardware. Compare with parts list to be sure all parts are present. If any part(s) are missing or damaged, phone, fax, or mail to our Customer Service Department. For efficient and speedy service, please indicate the model number and code letter of part(s) needed.

ATTENTION: SOME NUMBERED PARTS LISTED ON THE INSTRUCTION SHEET MAY NOT BE IN PARTS BAG AS THEY MAY ALREADY BE ASSEMBLED. CAREFULLY CHECK PARTS AND PACKING MATERIALS PRIOR TO ORDERING REPLACEMENTS.

HARDWARE ILLUSTRATIONS

Tools required: Screwdriver

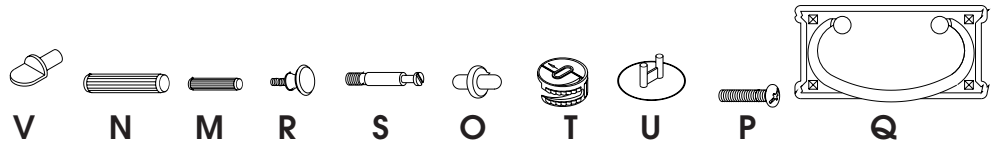

IMPORTANT NOTE: Follow instructions listed below in the proper sequence as numbered to assure fast, easy and correct assembly.

- Note:** Upon opening, thoroughly clean all wood surfaces with furniture polish to remove dust and dirt that may have settled onto finish during shipment.
- Place parts on a soft cloth. Insert Large Dowels (N) into bottom of Divider (C). Insert Small Dowels (M) into ends of Short Cross Bars (I). Insert Dowels (M,N) extending from Divider (C) and Short Cross Bars (I) into top of Base (D). Insert Dowels (M,N) extending from top of Short Cross Bars (I) into Magazine Cross Bar (J). (See ill. #1)
- Insert Large Dowels (N) into ends of Magazine Cross Bar (J) and Front and Back Cross Bars (K,W). Tighten Cam-bolts (S) into threaded holes in Left and Right Side Panels (A,B). Insert Dowels (N) extending from Front and Back Cross Bars (K,W) and Magazine Cross Bar (J) into Side Panels (A,B) while inserting Cam-bolts (S) extending from Side Panels (A,B) into sides of Base (D). Insert Hinge Pins (O) into top and bottom corners of Door (G). Insert Hinge Pins (O) extending from Door (G) into top of Base (D) and underside of Front Cross Bar (K). Insert Dowels (N) through Front and Back Cross Bars (K,W) and into top of Divider (C). Insert Cam-locks (T) into holes on underside of Base (D) with slot for screwdriver facing outward. Rotate Cam-locks (T) clockwise to secure Cam-bolts (S). Insert Machine Screws (P) through Door (G) and tighten into Handles (Q). NOTE: Front Cross Bar (K) has latches on underside. (See ill. #2)
- Slide Back (F) into groove between Side Panels (A,B). (See ill. #3)

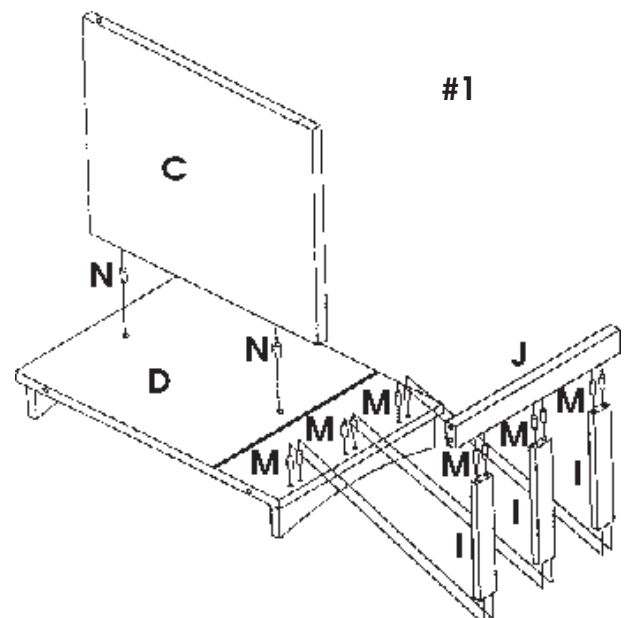

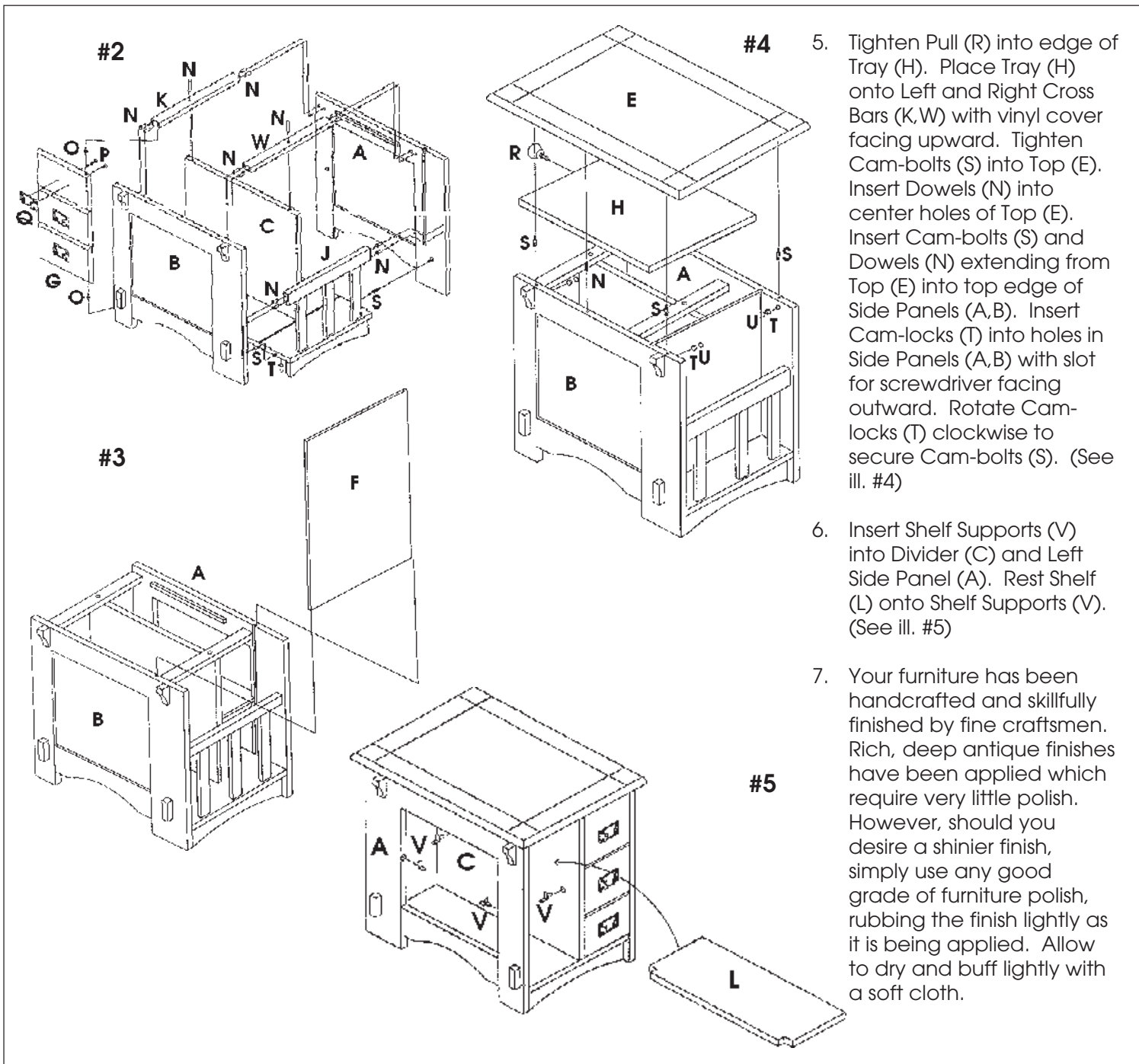

5. Tighten Pull (R) into edge of Tray (H). Place Tray (H) onto Left and Right Cross Bars (K,W) with vinyl cover facing upward. Tighten Cam-bolts (S) into Top (E). Insert Dowels (N) into center holes of Top (E). Insert Cam-bolts (S) and Dowels (N) extending from Top (E) into top edge of Side Panels (A,B). Insert Cam-locks (T) into holes in Side Panels (A,B) with slot for screwdriver facing outward. Rotate Cam-locks (T) clockwise to secure Cam-bolts (S). (See ill. #4)

6. Insert Shelf Supports (V) into Divider (C) and Left Side Panel (A). Rest Shelf (L) onto Shelf Supports (V). (See ill. #5)

7. Your furniture has been handcrafted and skillfully finished by fine craftsmen. Rich, deep antique finishes have been applied which require very little polish. However, should you desire a shinier finish, simply use any good grade of furniture polish, rubbing the finish lightly as it is being applied. Allow to dry and buff lightly with a soft cloth.

IF YOU HAVE A PROBLEM, WE WANT TO HAVE THE OPPORTUNITY TO MAKE IT RIGHT!

Should there be any missing or defective part(s),

FAX this form to (310) 841-0842

or call and ask for Customer Service at (800) 622-4456 or (310) 204-2224. Have your model number and part code letter handy.

MODEL NO. 356C

© 1999 Powell

Part Letter	Description	Quantity

Name _____
 Address _____

 Daytime Phone () _____
 Reason for Replacement _____

 Place of Purchase _____